

REVISIONS				
ECN	REV	DESCRIPTION	DATE	APPROVED
2088	A	RELEASED FOR PRODUCTION	03/25/2003	

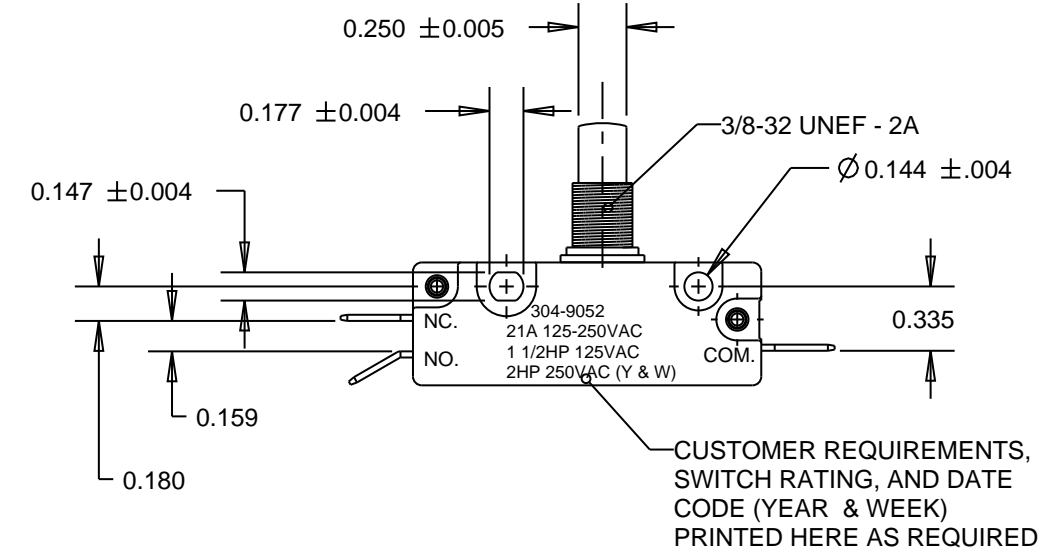
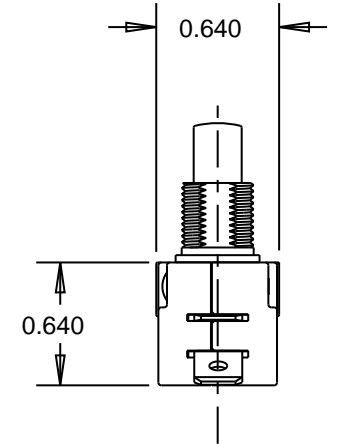
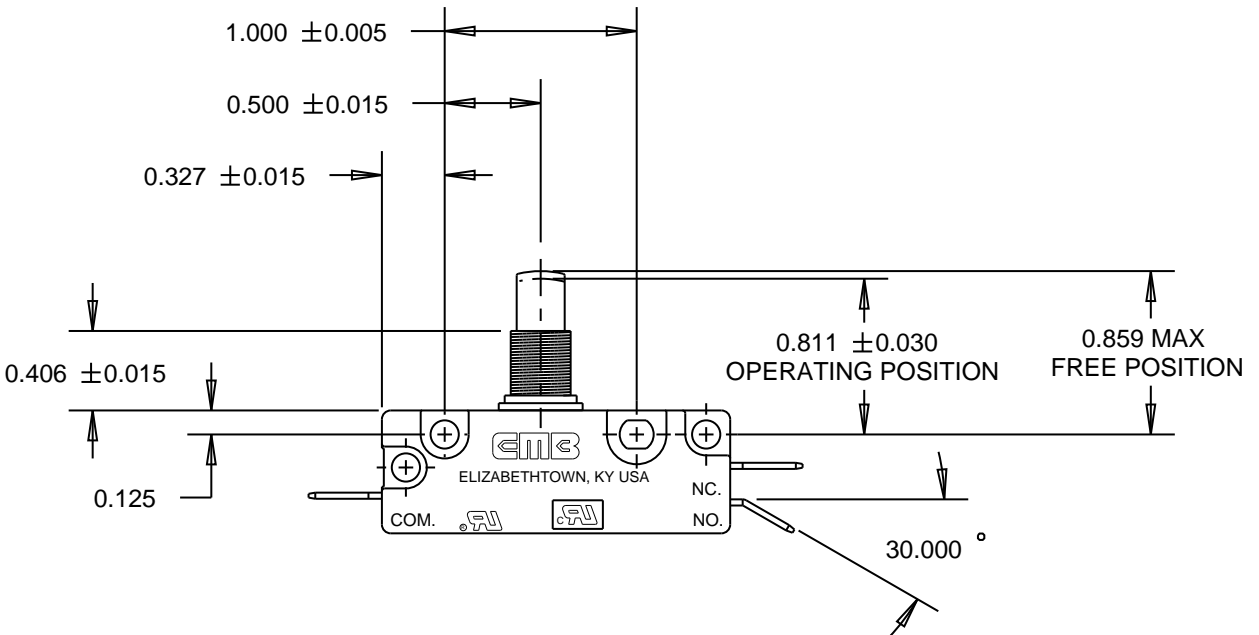
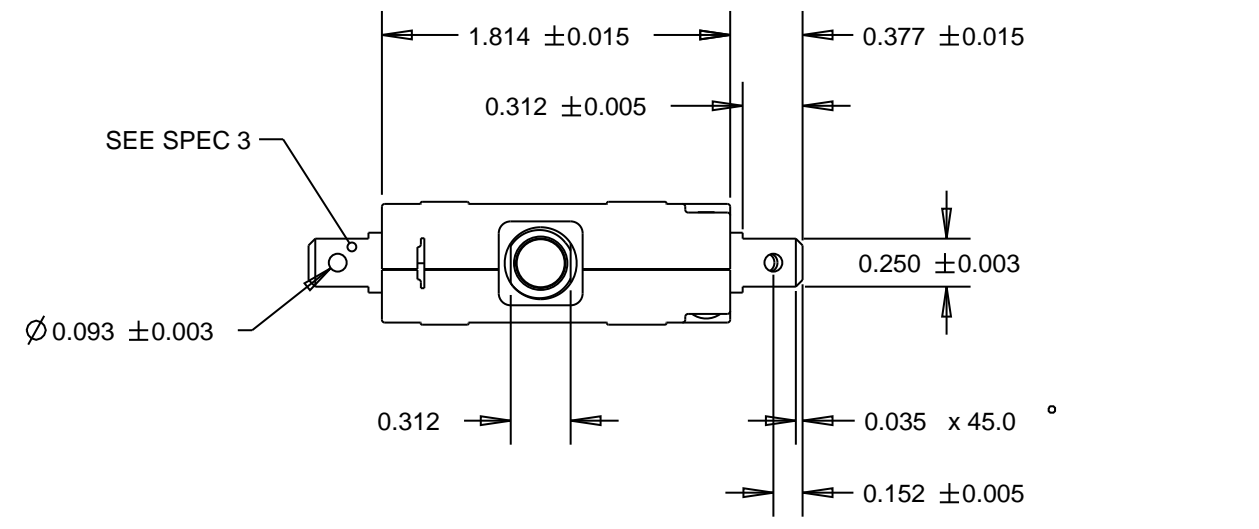

**SPECIFICATIONS:**

- MODEL 301 SERIES SNAP-ACTION SWITCH S.P.S.T. NORMALLY OPEN CIRCUITRY WITH POWER LOAD SWITCHING CAPACITY - 21 AMPS 125-250 VAC, 1 1/2 HP 125 VAC, 2 HP 250 VAC  
  
OPERATING FORCE - 20 OZ. MAX  
RELEASE FORCE - 3 OZ. MIN  
PRETRAVEL - 0.070 MAX  
OVERTRAVEL - 0.100 MIN  
MOVEMENT DIFFERENTIAL - 0.035 MAX
- SWITCH IS U.L. RECOGNIZED AND C.S.A. CERTIFIED
- TERMINALS - 0.032 BRASS QUICK CONNECT MALE TAB
- 3/8-32 UNEF-2B HEX PANEL NUTS TO BE BULK PACKED WITH EACH SHIPMENT (1 PER SWITCH)

UNLESS OTHERWISE SPECIFIED	SIGNATURES	DATE
DIMENSIONS ARE IN INCHES TOLERANCE ON	DRAWN MPB	25-Mar-03
2 PL DECIMALS ±	CHECKED	
3 PL DECIMALS ± 0.010	APPROVED	
ANGLES ± 2.000		
FRACTIONS ±		
NOTICE THESE DRAWINGS AND ALL SPECIFICATIONS ARE THE SOLE PROPERTY OF EMB CORP. AND SHALL NOT BE USED AS THE BASIS FOR MANUFACTURING OR SALE WITHOUT PRIOR WRITTEN PERMISSION.	▼ PROCESS CAPABILITY REQUIRED ▽ MONITORING REQUIRED CRITICAL CHARACTERISTIC CONTROL QP3 - 3.2.4	

 ELIZABETHTOWN, KENTUCKY		
<b>GENERAL PURPOSE SNAP ACTION SWITCH</b>		
SIZE <b>B</b>	DWG NO <b>304-9052</b>	
SCALE 1.000	FILE NO. 304-9052	SHEET 1 of 1

DISTR TO