

# 16, 17

- Snap fits into .830 x 1.450" panel cutout
- Incandescent and neon illumination
- Single or dual lenses
- Dummy (hole plugs) available

### SPECIFICATIONS

Body Material:	Nylon	Panel Thickness:	0.030" to 0.240"
Lens Material:	Polycarbonate	Certifications:	See Page 1
Wire Gauge:	18 ga.		

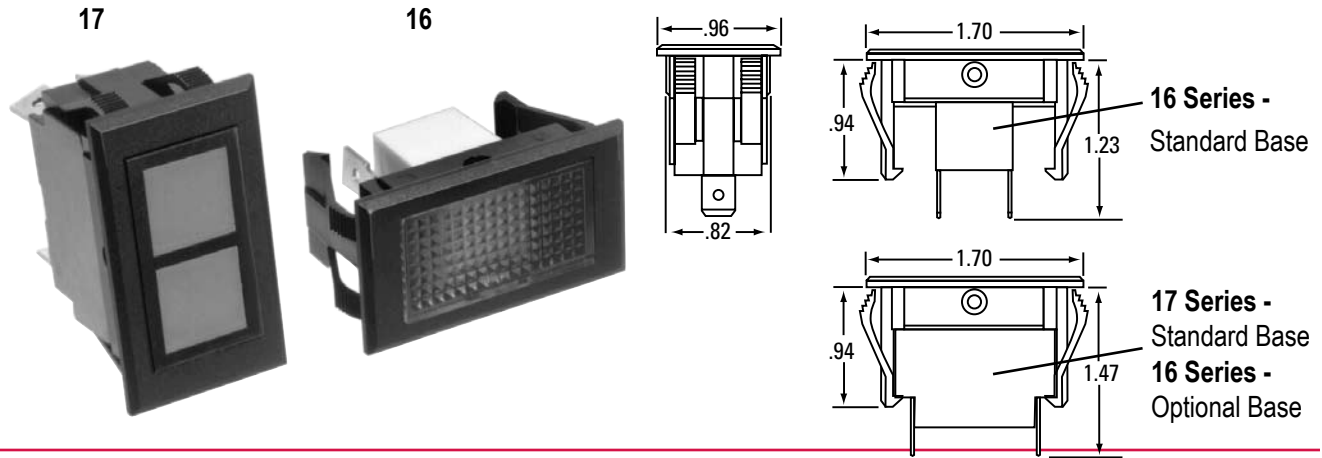

Series	Lamp		Termination		Base		Bezel		Lens				
XX	XX	-	X	-	X	X	-	XXX	X	X			
	Voltage	Type	Code	Style	Code	Color	Code	Finish	Code	Style	Code	Color	Plain
16	N/A	DUMMY	00	N/A	0	Std.	0	Matte Black	5	Single Translucent	131	Red	1
17	6	INCAND	32	.187 Tabs	3	Optional	X	Matte White	6	Single Diamond	133	Amber	2
	14	INCAND	35	.250 Tabs	4					Single Fine Diamond	137	Clear	3
	28	INCAND	39	Solder	5							Green	4
	125	NEON	50							Dual Translucent	141	Blue	5
	250	NEON	52							Dual Fine Diamond	147	White	6
		Special	XX									Black	7
												Color	Marked
												Red	A
												Amber	B
												Clear	C
												Green	D
												Blue	E
												White	F

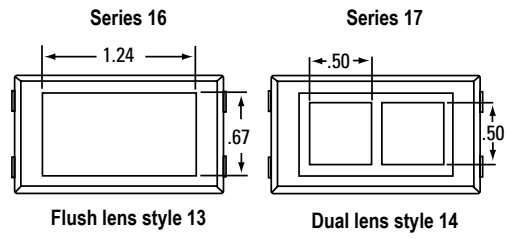

Series	Code
16	0
17	Repeat selection from lens color choices above
	<b>White is Translucent</b>
	<b>Clear is Transparent</b>

### ADDITIONAL OPTIONS AVAILABLE:

Contact Factory